

Motorized Reels

Motorized Rewind Reels

The Extreme Reel

The 30 Series motorized reels are equipped to handle applications that require numerous extension and retraction cycles. It's the reel that **works all day, every day**. With multiple circuit rating options and the capability to manage over 100' of cable, motorized reels can be adapted to fit your needs.

- Motorized reel options include, air, electric and hydraulic
- Heavy-duty motor designed for heavy-duty usage
- Rugged dual triangular support with shaft bearings
- Multiple spool width options: Choose from 6", 12", 18", 22" or 28"
- Larger diameter cable capability up to .875" O.D.
- Low profile for critical space requirements

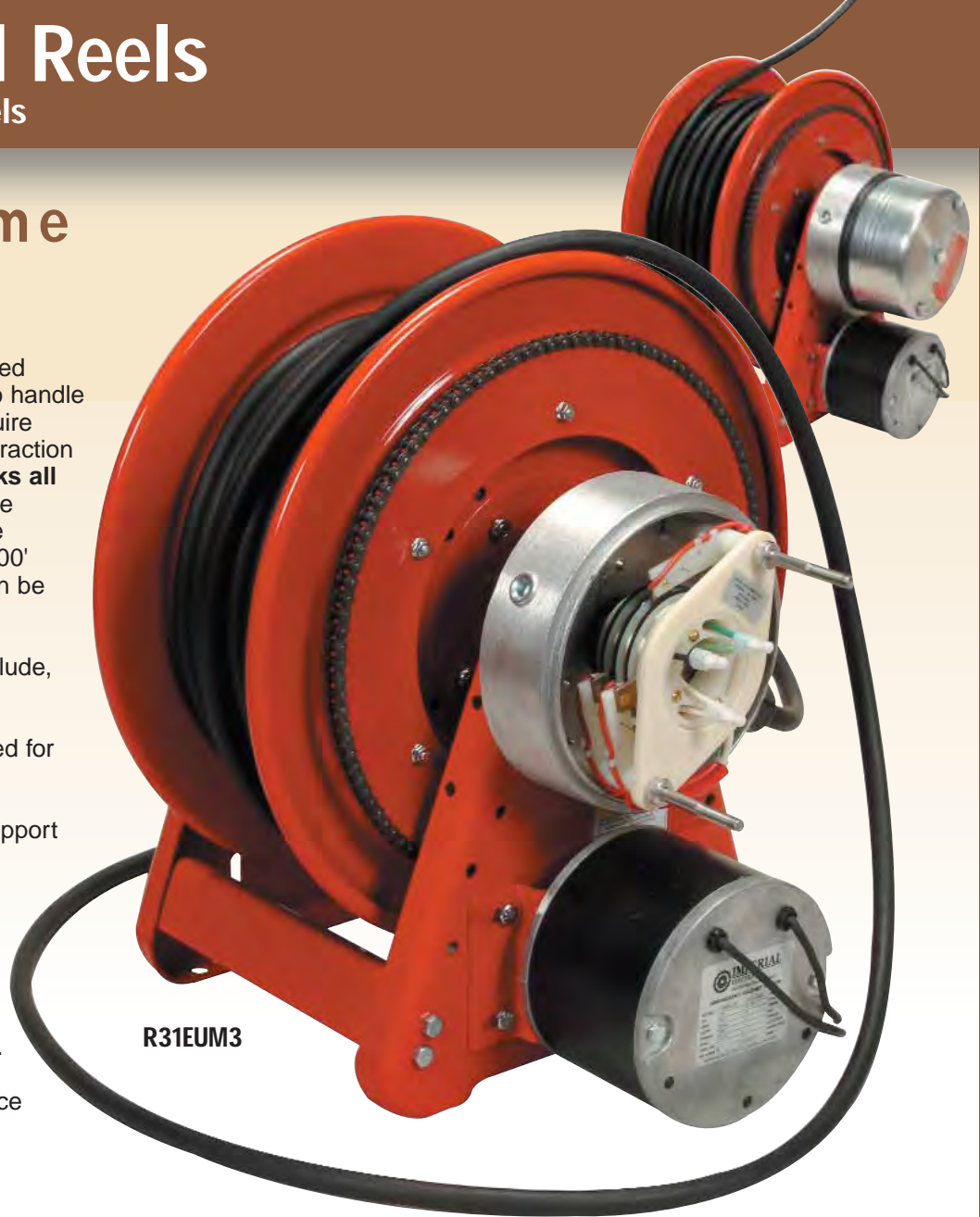

R31EUM3

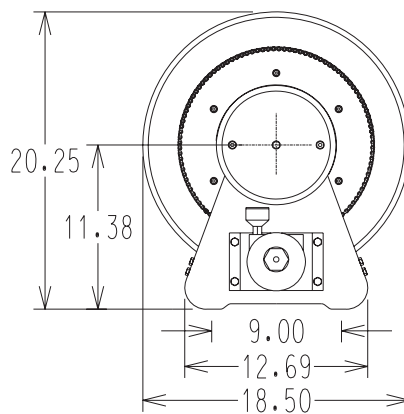
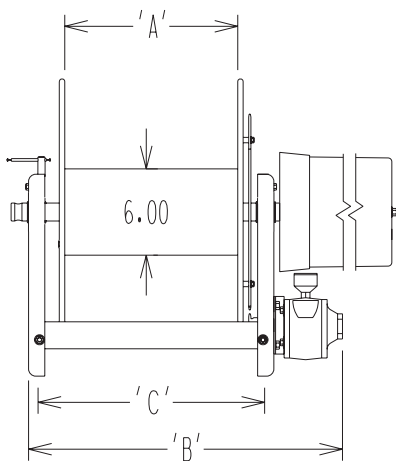

www.uea-inc.com

1-800-394-9986

Part Number	Dimension A	Dimension B	Dimension C
R32A (4.0 HP)	12.0"	23.25"	15.75"
R32A (1.5 HP)	12.0"	23.25"	15.75"
R32A (1.5 HP)	6.0"	17.25"	9.75"

Standard Features for the Motorized Reels Include:

- Cable standard: SOW-A
- 5' of stationary cable length included
- Adjustable cable bumpers allow varying cable length outside the reel
- Lock pin to prevent free spooling