

# 80 Series

Large Capacity Spring Driven Reel

## The Rugged Reel

The 80 Series reel features rugged durability to handle the rough jobs. This reel offers the longest extension of cable up to 100'. With versatile mounting options and multiple circuit ratings available, this series is perfect to meet many different specifications.

- Dual support saddle frame for structural strength
- Accepts cable up to .875" O.D.
- Spring motor options with many torque options
- Available in stainless steel to help with corrosive environments

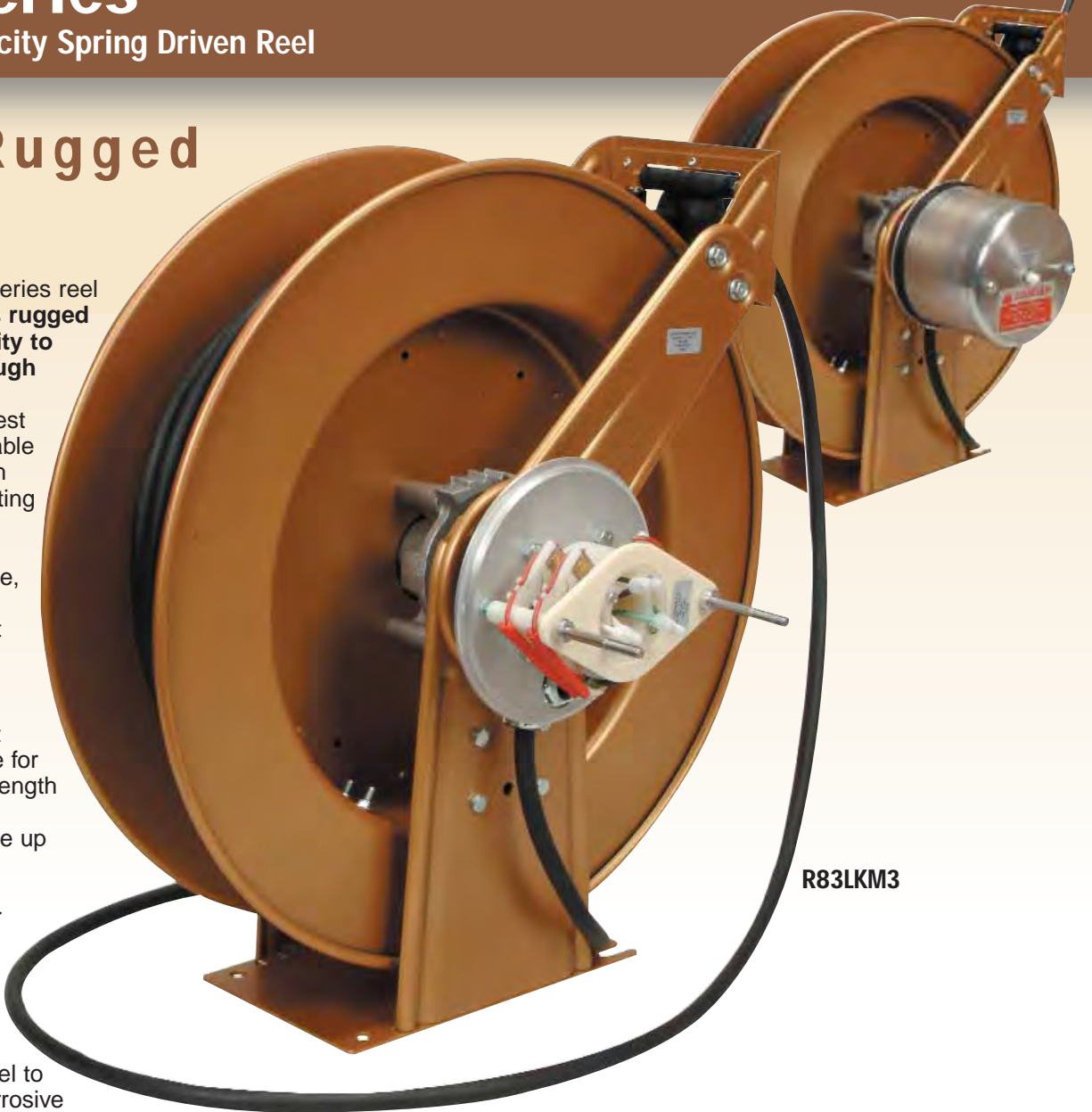

R83LKM3

### Standard Cable Reel Features Include:

- Varying guide arm positions allow floor, wall, ceiling or any custom mount
- Weather-proofed spring motor gasket ensures long life
- Nylon guide rollers eliminate cable pinching and reduce drag

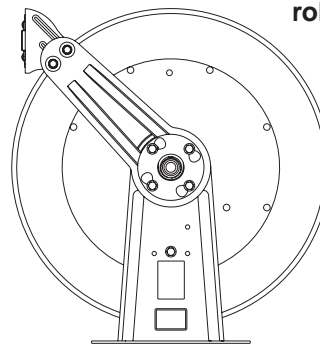
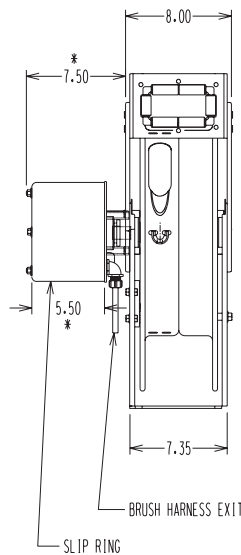
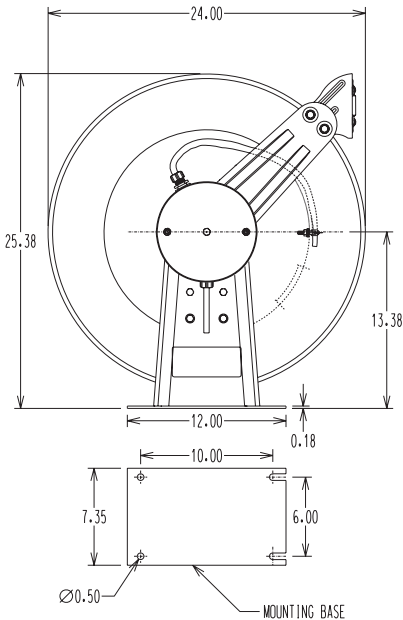

\* - DIMENSION MAY VARY PER SLIP RING NEEDED.

