

# 50 Series

Small Capacity Spring Driven Models

## The Compact Workhorse

Looking for a **small yet heavy-duty** reel? The 50 Series is your answer! With a larger spool capacity than the 40 Series, but a more compact size than the 70 Series, this reel is able to meet many of your smaller-application needs.

- Ideal for multi high conductor count cables of 5 or more
- Larger spool capacity for longer, heavier O.D. cable up to .73"
- Available in stainless steel to help with corrosive environments

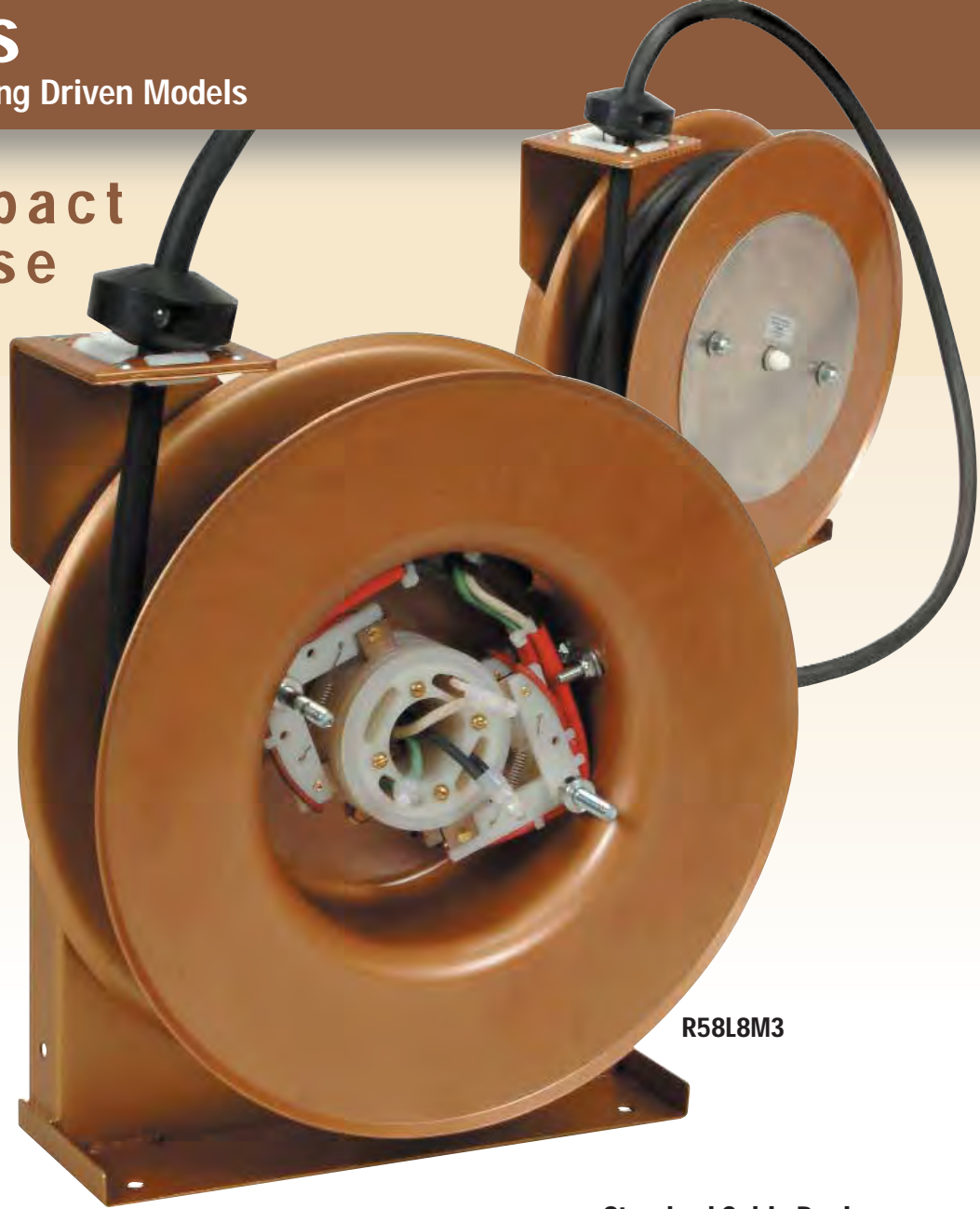

R58L8M3

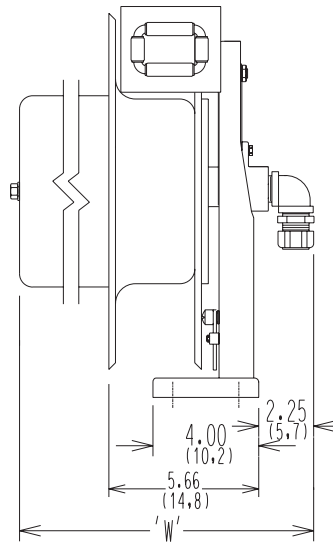
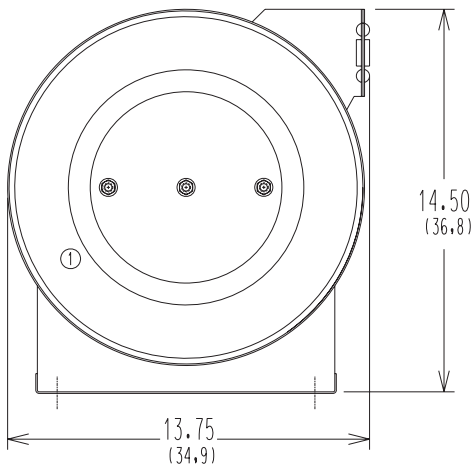

OVERALL WIDTH 'W' DEPENDENT UPON NUMBER AND CURRENT RATING OF CIRCUITS.

### Standard Cable Reel Features Include:

- Cable standard: SOW-A
- 5' of stationary cable length included
- Adjustable cable bumpers allow varying cable length outside the reel
- Latch mechanism guarantees de-reeled cable will lock at desired length
- Constant tension reels available
- Varying guide arm positions allow floor, wall, ceiling or any custom mount
- Weather-proofed spring motor gasket ensures long life
- Nylon guide rollers eliminate cable pinching and reduce drag

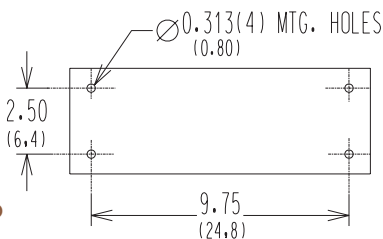



R59L6L3

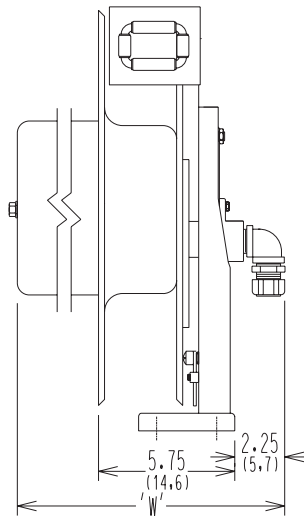
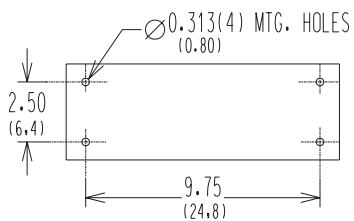
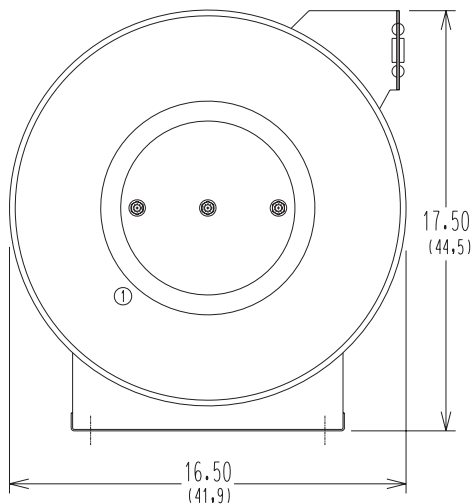

OVERALL WIDTH 'W' DEPENDENT UPON  
NUMBER AND CURRENT RATING OF CIRCUITS.



[www.uea-inc.com](http://www.uea-inc.com)

1-800-394-9986

